

FLOCRYL™ MBA



SNF FLOERGER
41, rue Jean Huss
42028 Saint-Etienne Cedex 1 FRANCE
Tel : + 33 (0)4 77 47 66 00
Fax : + 33 (0)4 77 47 66 96
floerger@snf.fr

SNF FLOERGER®

GUTENBERG ON LINE REGIONS - Tél. 04 77 42 35 00 / 131001

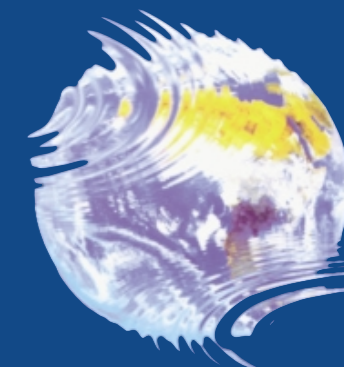

SNF FLOERGER®

FLOCRYL™ MBA

Introduction

FLOCRYL™ MBA or N, N' methylenebisacrylamide is a bifunctional monomer, with two identical unsaturated double bonds, widely used as a crosslinker in many fields of application.

It can be used as an effective crosslinking agent in the preparation of a wide range of polymers and forms highly crosslinked polymers during copolymerization with either acrylic or vinyl monomers such as acrylonitrile, acrylamide, acrylic acid, acrylate esters, substituted acrylamide, and derivatives of those different compounds.

Uses

FLOCRYL™ MBA is an ideal raw material for a wide variety of applications. It is especially suited to the preparation of crosslinked polymers used in :

- Adhesives
- Cosmetic thickeners
- Biological, pharmaceutical and personal home care products
- Catalysts
- Chromatographic materials
- Coagulating and flocculating agents
- Coatings
- Construction materials
- Ion exchange resins (anionic, cationic and ampholytic)
- Paper application
- Polyacrylamide gels for electrophoresis
- Soil grouting systems
- Superabsorbent polyacrylate resins used in diapers
- Textile thickeners



Reactivity

The normal vinyl addition polymerization is possible with the monomer, but it should be noted that crosslinking properties are acquired in the first place by the existence of the double bonds in the molecule, rather than by a secondary reaction.

MBA is widely used for the ease of controlling its crosslinking properties in the different polymers formulations.

Copolymerization of acrylamide with N, N' methylenebisacrylamide produces a polymer gel with a nearly uniform distribution of pendant methyleneacrylamide groups. The pendant double bonds have the same reactivity as the first double bond of the monomer except for the restriction of mobility.

The polymerization is conducted in the same manner as the homopolymerization of acrylamide in aqueous solution.

The structure of the gels is varied by adjusting the base molecular weight of the polymer, the polymer concentration, and the methylenebisacrylamide concentration.



Chemical reactions

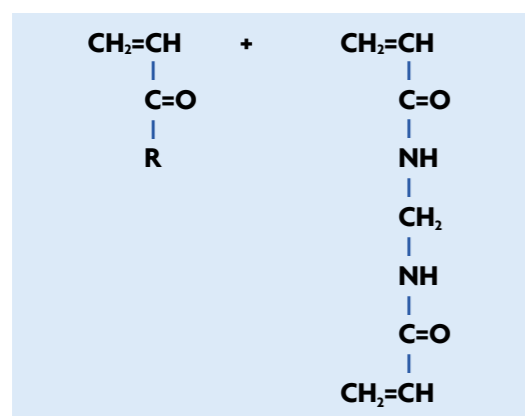

Polymerization reaction :

FLOCRYL™ MBA can be polymerized in emulsion, solution, suspension and gel polymerization in the presence of conventional vinyl polymerization catalyst as peroxides, azoic redox systems electron, UV light and by photopolymerization.

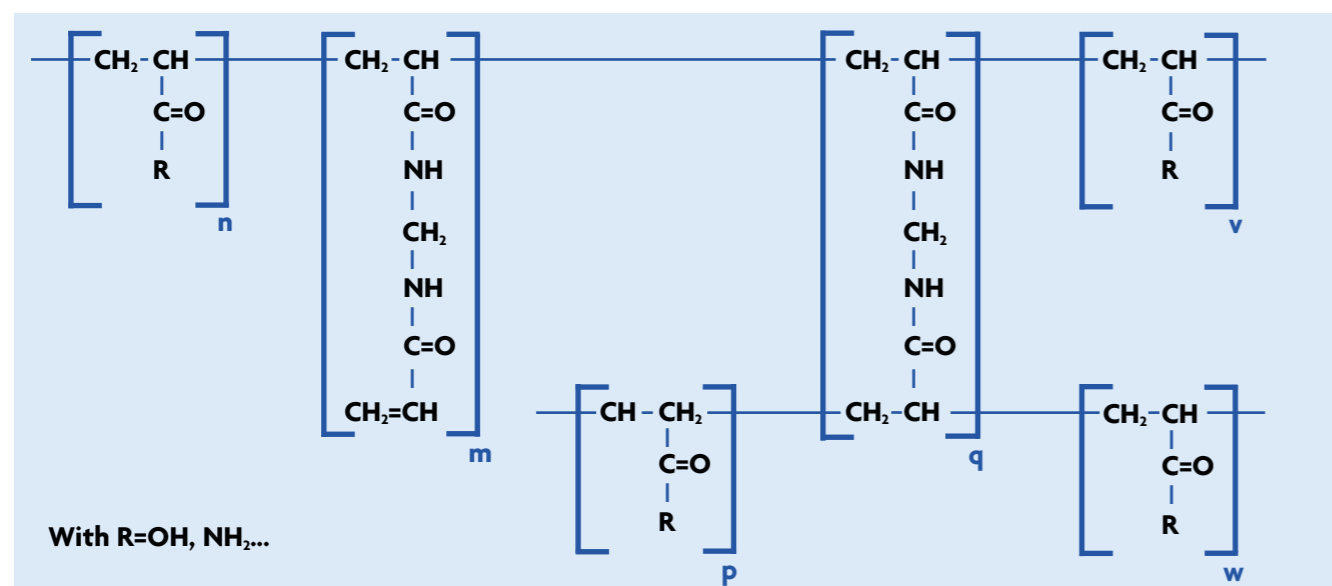

Reactions through vinyl groups :

These reactions are not very selective and mixtures of mono and disubstituted products are produced as well as some unreacted starting materials.

1. With amines :

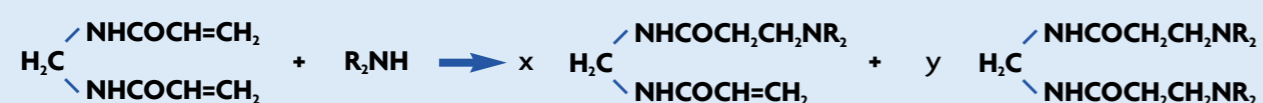

2. With hydroxy compounds :

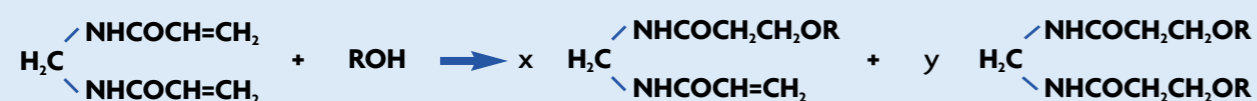

Reactions with formaldehyde :

N, N' methylenebisacrylamide reacts with formaldehyde in basic conditions to give a mixture of N, N' methylenebisacrylamide and N hydroxymethyl N, N' methylenebisacrylamide. The ratio between each compounds is not known. Although, this methylol compound cures to a hard film when heated at 150°C.

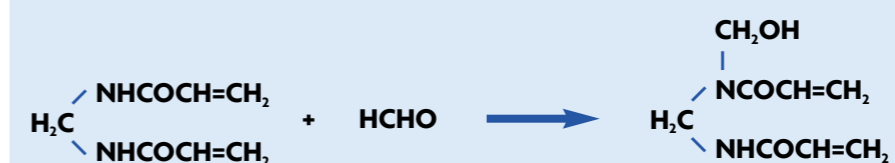

Reactions with thiols :

N, N' methylenebisacrylamide can be reacted with mono and/or difunctional thiols acids which add to the double bond of monomer.

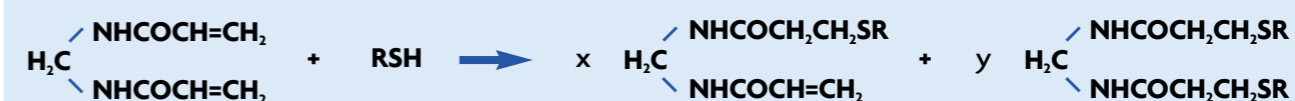

Diels-Alder adducts :

Diels Alder reaction can be undergo as follows :

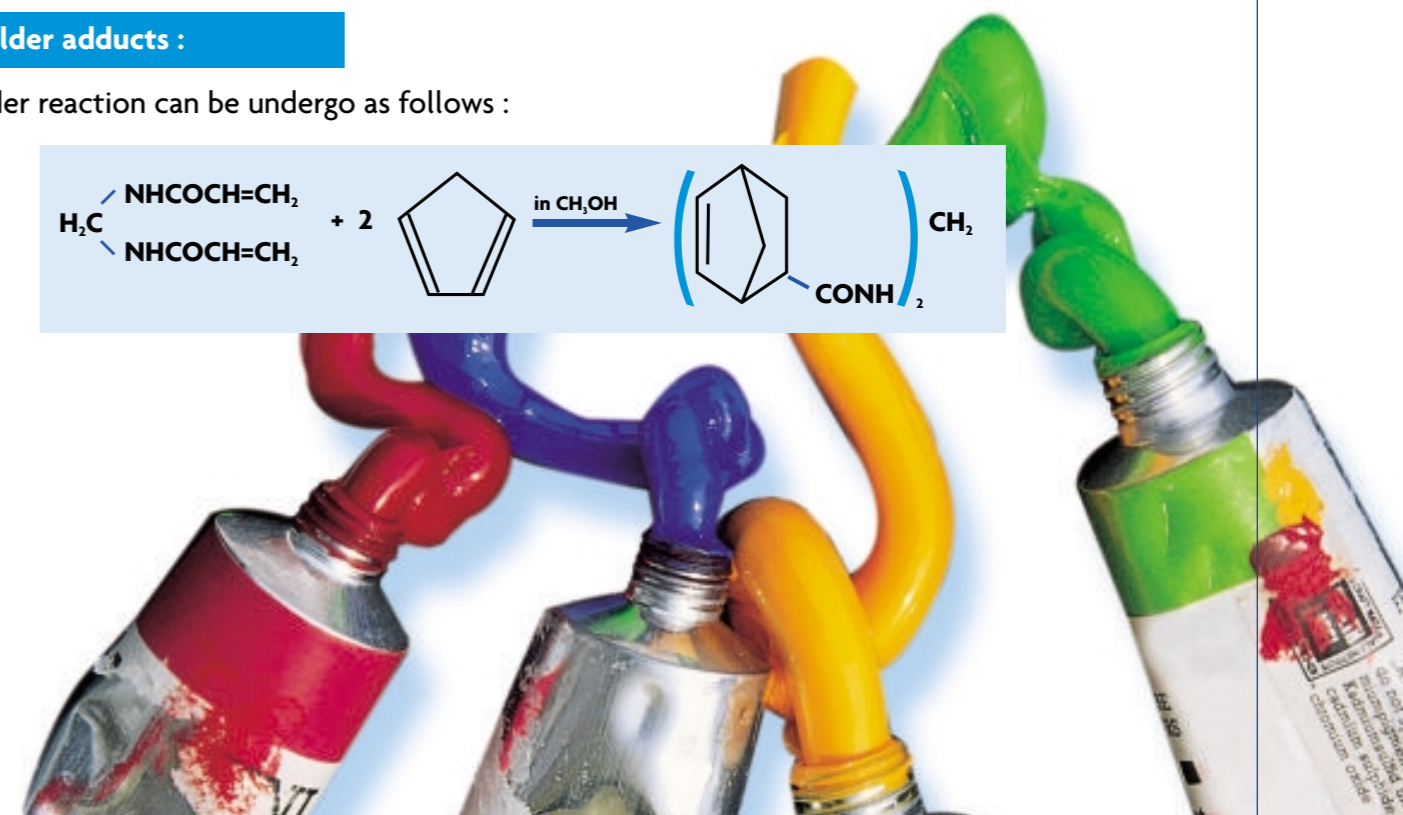
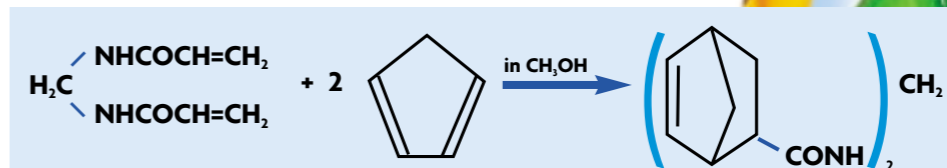

Specifications and Physical Properties

CAS Registry Number : 110-26-9

If the methods of analysis used to obtain these data are of interest to you, a technical representative from our analytical department can discuss them with you.

Product description

Appearance	White Crystalline solid
Molecular weight (g.mol ⁻¹)	154.17
Active content (%)	95.0 min.
Moisture content (%)	1.0 maxi.
Water insolubles (%)	0.5 maxi.
Melting point (°C)	> 300
Apparent density (at 30°C)	1.24

Solubility in water (g/100ml) :

at 10°C	2.0
at 25°C	3.0
at 50°C	6.5
at 90°C	42.0

Solubility in solvents (g/100ml) :

in acetone (at 30°C)	1.0
in benzene (at 30°C)	< 1.0
in chloroform (at 30°C)	0.3
in dioxane (at 30°C)	1.1
in ethanol (at 30°C)	5.4
in ethyl acetate (at 30°C)	0.4
in methanol (at 30°C)	8.2
in n-heptane (at 30°C)	< 0.02



Storage stability

FLOCRYL™ MBA can be stored at ambient temperature (5 - 30°C). Decomposition of MBA at high temperature gives water, carbon dioxide and nitrogen (no acrylamide released).

Toxicity

N, N' methylenebisacrylamide may be harmful by ingestion or inhalation. It is not irritating to rabbit eyes or skin.

Complete and up-to-date information on the toxicology of *FLOCRYL™ MBA* as well as instructions for its safe handling and use can be found in the Material Safety Data Sheet which is available from our Product Information & Regulatory Affairs Department.

Packaging

FLOCRYL™ MBA is supplied in 15 kg drums. Another packaging is also available on request.